

UNIVERSITY OF CAMBRIDGE INTERNATIONAL EXAMINATIONS  
International General Certificate of Secondary Education

**BIOLOGY**



Paper 6 Alternative to practical

**0610/06**

May/June 2005

Candidates answer on the Question Paper.  
No Additional Materials

**1 hour**

Candidate  
Name

--

Centre  
Number

--	--	--	--	--

Candidate  
Number

--	--	--	--

**READ THESE INSTRUCTIONS FIRST**

Write your name, Centre number and candidate number on all the work you hand in.

Write in dark blue or black pen in the spaces provided on the Question Paper.

You may use a pencil for any diagrams, graphs or rough working.

DO **NOT** WRITE IN THE BARCODE.

DO **NOT** WRITE IN THE GREY AREAS BETWEEN THE PAGES.

Do not use staples, paper clips, highlighters, glue or correction fluid.

You may use a calculator.

Answer **all** questions.

The number of marks is given in brackets [ ] at the end of each question or part question.

For Examiner's Use	
1	
2	
3	
<b>Total</b>	

This document consists of **10** printed pages and **2** blank pages.



**BLANK PAGE**

- 1 Catalase, an enzyme, is present in all living cells including those of potato and liver. It speeds up the breakdown of hydrogen peroxide as shown by the equation:

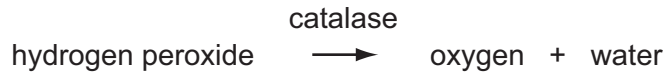

The oxygen is given off as a gas which can be collected over water, as shown in Fig. 1.1.

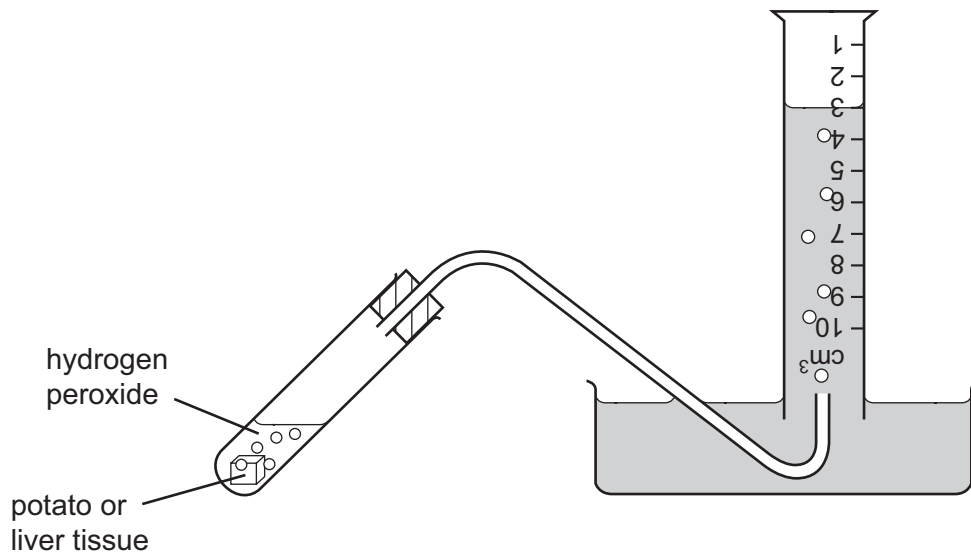





**Fig. 1.1**

Two different tissues, potato and liver, were used for this investigation. Samples, each of one gram, were prepared from both tissues. Some of the samples were left raw and others were boiled. Some samples were left as one cube and others were chopped into small pieces as shown in Table 1.1 on page 4.

2 cm<sup>3</sup> hydrogen peroxide was added to each sample. The volume of oxygen produced in five minutes was collected in the measuring cylinders, as shown in Table 1.1.

Table 1.1

For  
Examiner's  
Use

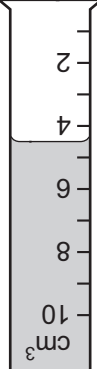
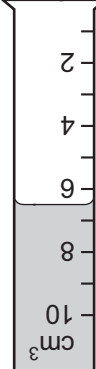
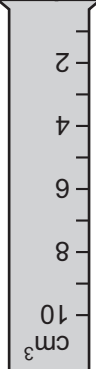
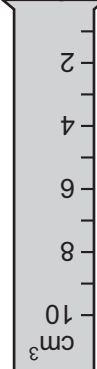
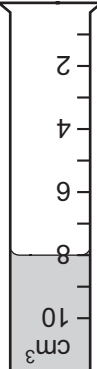
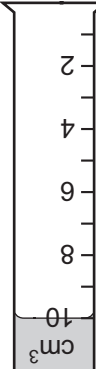
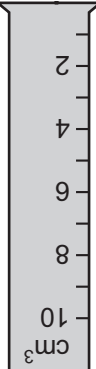
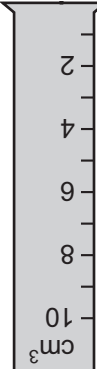
sample	A	B	C	D
treatment	 raw	 raw	 boiled	 boiled
results for potato				
results for liver				

- (a) (i) Complete Table 1.2, by reading the values for oxygen collected in the measuring cylinders in Table 1.1.

Table 1.2

tissue	volume of oxygen collected from each sample / cm <sup>3</sup>			
	A	B	C	D
potato				
liver				

[2]

(ii) Plot the volumes of oxygen collected from the samples as a bar chart on the grid.

For  
Examiner's  
Use

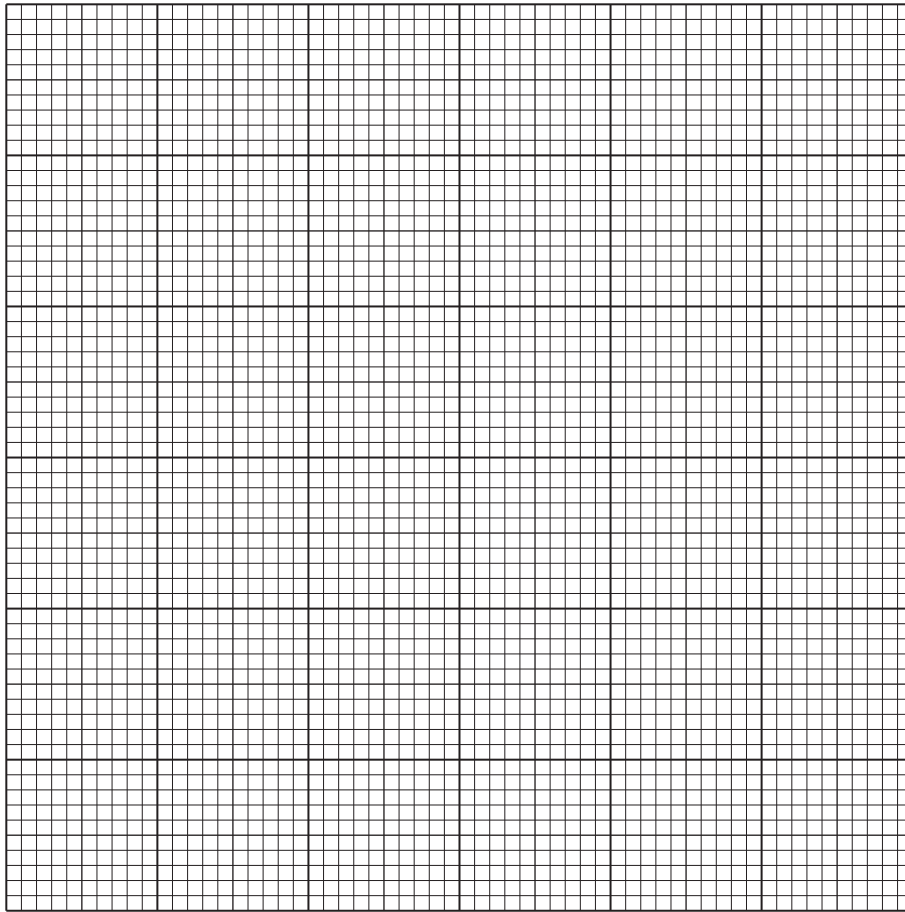

[4]

(iii) Describe the difference in results between sample **A** for potato and sample **A** for liver.

.....  
.....  
..... [2]

(iv) There is a difference between the samples for **A** and **B** for liver.

Suggest an explanation for this difference.

.....  
.....  
..... [2]

(b) State the importance of samples **C** and **D** in this investigation.

.....  
..... [1]

(c) Suggest how you could test that the gas given off was oxygen.

.....  
..... [1]

[Total 12]

*For  
Examiner's  
Use*

- 2 Fig. 2.1 shows an insect-pollinated flower, cut in half longitudinally.



**Fig. 2.1**

- (a) (i) Make a large drawing of the cut surface of the half-flower shown in Fig. 2.1.

[4]

- (ii) On your drawing, label each of the following with a label line and the letter **X**, **Y** or **Z**:

**X** for the part of the flower in which the pollen grains are produced,

**Y** for the part of the flower to where the pollen grains are transferred during pollination,

**Z** for the part of the flower through which the pollen tube grows, shortly after pollination.

[3]

(b) (i) Insects such as the honey bee, *Apis mellifera*, collect nectar to make into honey. Describe how you could test a sample of honey for the presence of each of the following:

reducing sugar; .....

.....

.....

starch. ....

..... [3]

(ii) Honey contains reducing sugar.

State the colour change you would observe during the reducing sugar test in (b) (i).

..... [1]

(c) Fig. 2.2 shows one pollen grain, as seen with the aid of an electron microscope. This pollen grain has been magnified 200 times.

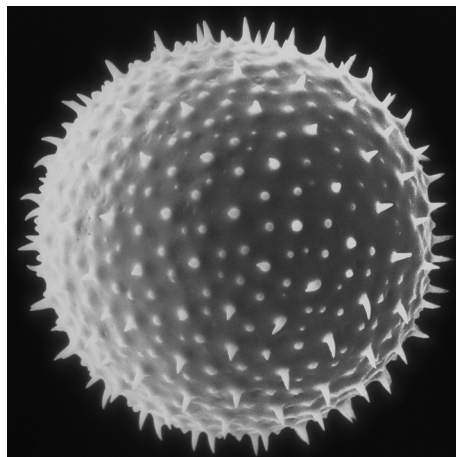

Fig. 2.2

(i) Calculate the actual size of this grain. Show your working.

actual size ..... [2]

(ii) State **one** feature visible in Fig. 2.2, that suggests that this pollen grain is from an insect-pollinated flower.

..... [1]



(d) It has been suggested that petal colour is important to attract insects to collect nectar and to pollinate the flowers.

(i) Outline how you would carry out an investigation to find out which petal colour would attract most insects.

.....

.....

.....

.....

.....

.....

..... [4]

(ii) Some insect-pollinated flowers do **not** have brightly coloured petals to attract insects to collect nectar.

Suggest how insects might be attracted to these flowers.

.....

..... [1]

[Total 19]

- 3 Two cress seeds were germinated in shallow dishes, which were placed in boxes as shown in Fig. 3.1. The boxes were placed by a sunlit window.

For  
Examiner's  
Use

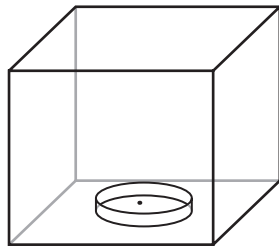

clear plastic box

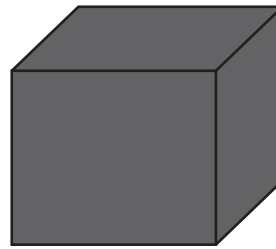

box made of black card

**Fig. 3.1**

The dishes were removed from the boxes after a week and the seedlings observed.

The seedlings differed in appearance, as shown in Fig. 3.2.

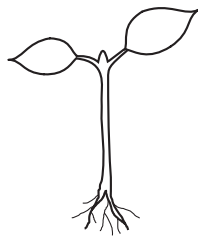

the seedling from  
the clear plastic box



the seedling from  
the box made  
of black card

**Fig. 3.2**

- (a) (i) Complete the table to describe two differences, visible in Fig. 3.2, between the seedling from the clear plastic box and the seedling from the box made of black card.

seedling from the clear plastic box	seedling from the box made of black card
1 .....	.....
2 .....	.....

[2]

(ii) Outline how this method could be improved to obtain more accurate and reliable results.

.....

.....

.....

.....

.....

.....

.....

.....

..... [4]

Fig. 3.3 shows a box with a slit in one side and the seedling that was grown in the box.

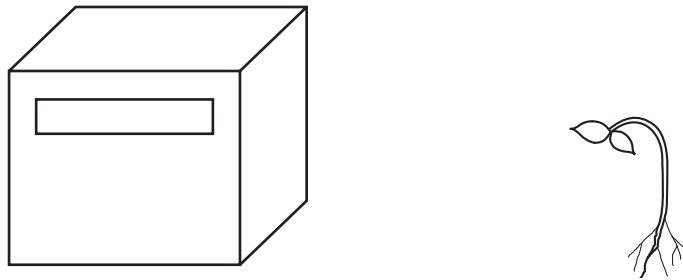

Fig. 3.3

(b) Describe and explain the appearance of the seedling grown in this box.

.....

.....

.....

.....

..... [3]

[Total 9]

---

*Copyright Acknowledgements:*

Fig. 2.1      © DR JEREMY BURGESS / SCIENCE PHOTO LIBRARY

Permission to reproduce items where third-party owned material protected by copyright is included has been sought and cleared where possible. Every reasonable effort has been made by the publisher (UCLES) to trace copyright holders, but if any items requiring clearance have unwittingly been included, the publisher will be pleased to make amends at the earliest possible opportunity.

University of Cambridge International Examinations is part of the University of Cambridge Local Examinations Syndicate (UCLES), which is itself a department of the University of Cambridge.