

1 (a) Alex has \$20 and Bobbie has \$25.

0580/42/O/N/17

(i) Write down the ratio Alex's money : Bobbie's money in its simplest form.

..... [1]

(ii) Alex and Bobbie each spend $\frac{1}{5}$ of their money.

Find the ratio Alex's remaining money : Bobbie's remaining money in its simplest form.

..... [1]

(iii) Alex and Bobbie **then** each spend \$4.

0580/42/O/N/17

Find the new ratio Alex's remaining money : Bobbie's remaining money in its simplest form.

..... [2]

Q1 (b) (i) The population of a town in the year 1990 was 15 600.
The population is now 11 420.

0580/42/O/N/17

Calculate the percentage decrease in the population.

.....% [3]

(ii) The population of 15 600 was 2.5% less than the population in the year 1980.

Calculate the population in the year 1980.

..... [3]

- Q1(c)** Chris invests \$200 at a rate of $x\%$ per year simple interest.
At the end of 15 years the total interest received is \$48.

0580/42/O/N/17

Find the value of x .

$$x = \dots\dots\dots [2]$$

- (d)** Dani invests \$200 at a rate of $y\%$ per year compound interest.
At the end of 10 years the value of her investment is \$256.

0580/42/O/N/17

Calculate the value of y , correct to 1 decimal place.

$$y = \dots\dots\dots [3]$$

2 (a)

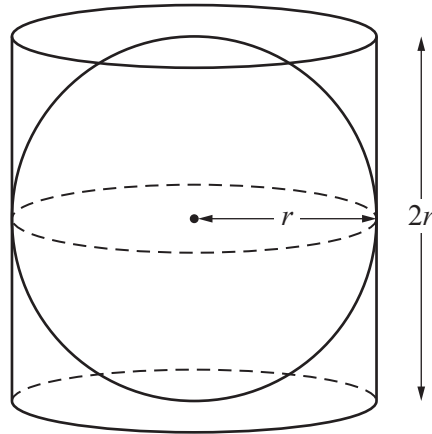
NOT TO
SCALE

A sphere of radius r is inside a closed cylinder of radius r and height $2r$.

[The volume, V , of a sphere with radius r is $V = \frac{4}{3}\pi r^3$.]

(i) When $r = 8$ cm, calculate the volume inside the cylinder which is **not** occupied by the sphere.

..... cm³ [3]

Q2A (ii) Find r when the volume inside the cylinder **not** occupied by the sphere is 36 cm³.

$r =$ cm [3]

Q2 (b)

0580/42/O/N/17

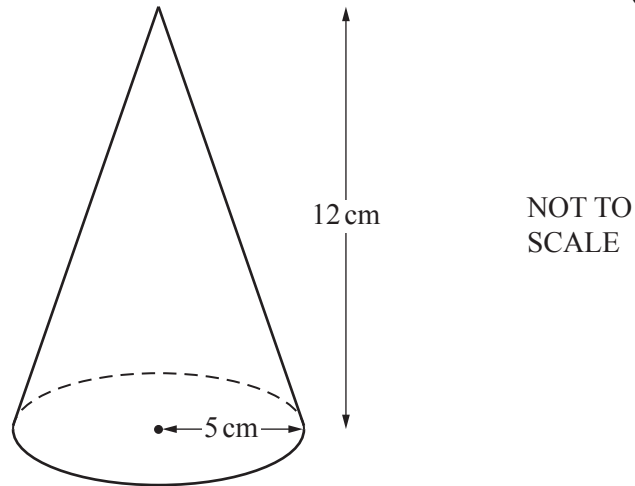

The diagram shows a solid cone with radius 5 cm and perpendicular height 12 cm.

- (i) The **total** surface area is painted at a cost of \$0.015 per cm^2 .

Calculate the cost of painting the cone.

[The curved surface area, A , of a cone with radius r and slant height l is $A = \pi rl$.]

\$ [4]

- (ii) The cone is made of metal and is melted down and made into smaller solid cones with radius 1.25 cm and perpendicular height 3 cm.

Calculate the number of smaller cones that can be made.

0580/42/O/N/17

..... [3]

3

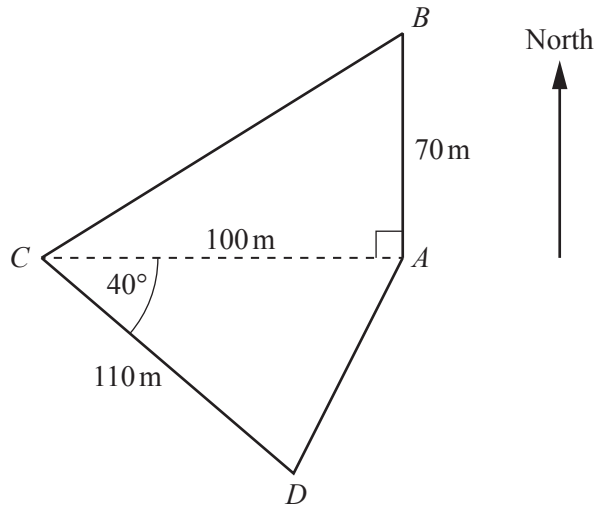

NOT TO SCALE

The diagram shows a field *ABCD*.

(a) Calculate the area of the field *ABCD*.

.....m² [3]

Q3 (b) Calculate the perimeter of the field *ABCD*.

..... m [5]

Q3(c) Calculate the shortest distance from A to CD .

0580/42/O/N/17

..... m [2]

Q3(d) B is due north of A .

0580/42/O/N/17

Find the bearing of C from B .

..... [3]

4 (a)

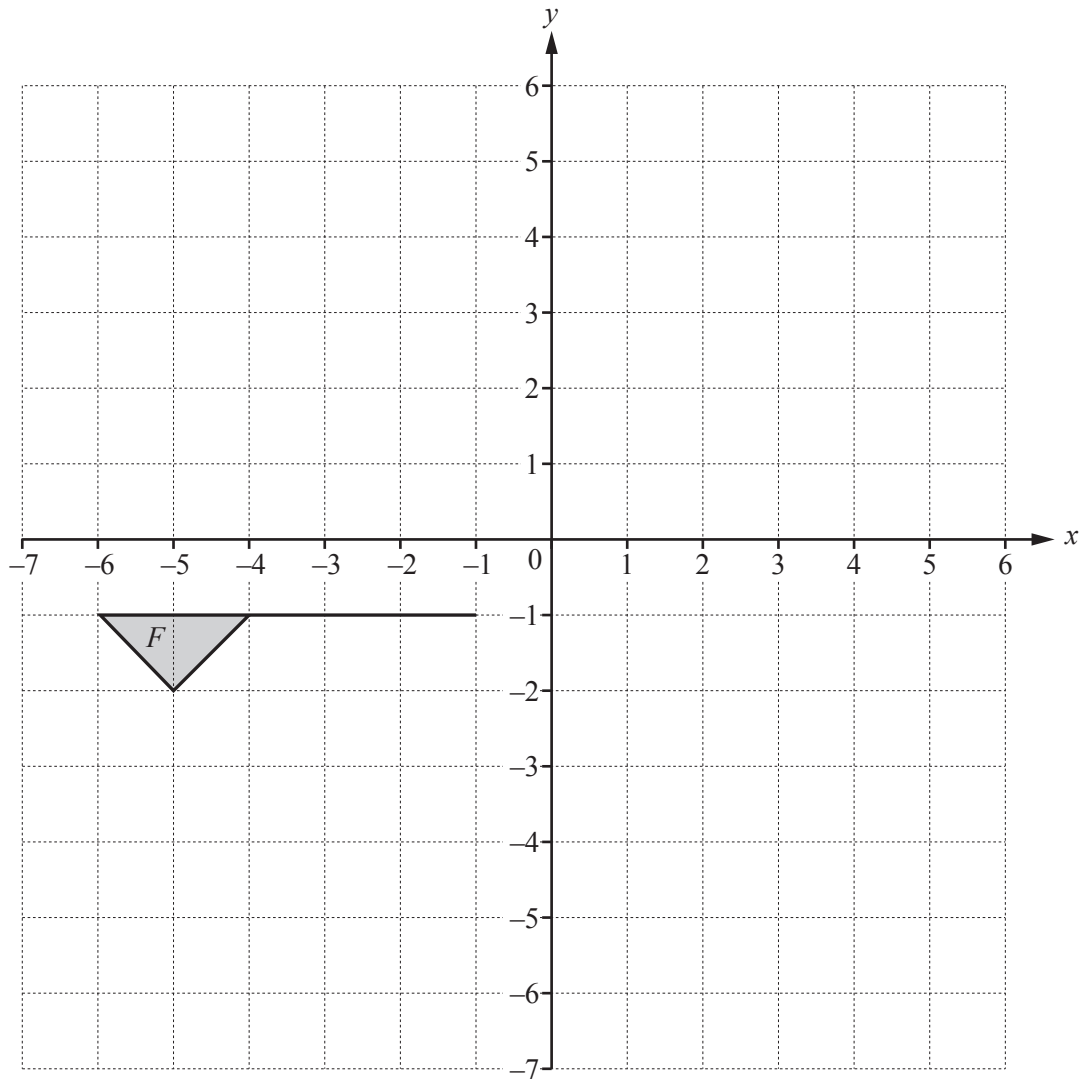

Draw the image of

- (i) flag F after translation by the vector $\begin{pmatrix} 6 \\ -2 \end{pmatrix}$, [2]
- (ii) flag F after rotation through 180° about $(-2, 0)$, [2]
- (iii) flag F after reflection in the line $y = x$. [2]

(b)

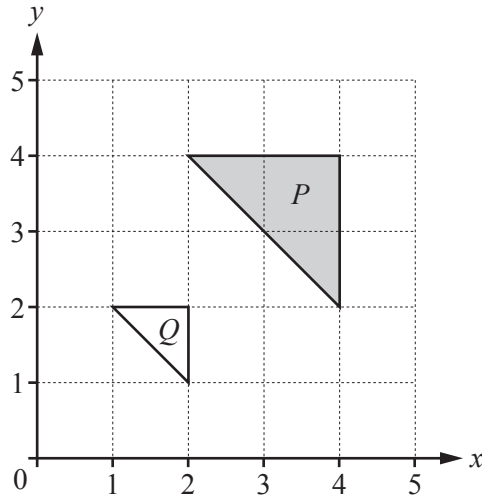

(i) Describe fully the **single** transformation that maps triangle P onto triangle Q .

.....
 [3]

(ii) Find the matrix that represents this transformation.

$\left(\begin{array}{cc} & \\ & \end{array} \right)$ [2]

(c) The point A is translated to the point B by the vector $\begin{pmatrix} 4u \\ 3u \end{pmatrix}$.

$|\vec{AB}| = 12.5$

Find u .

$u = \dots\dots\dots$ [3]

5 $y = \frac{x^3}{8} - \frac{2}{x^2}, x \neq 0$

(a) Complete the table of values.

x	0.5	1	1.5	2	2.5	3	3.5
y	-8.0	-1.9	-0.5	0.5	1.6		

[2]

(b)

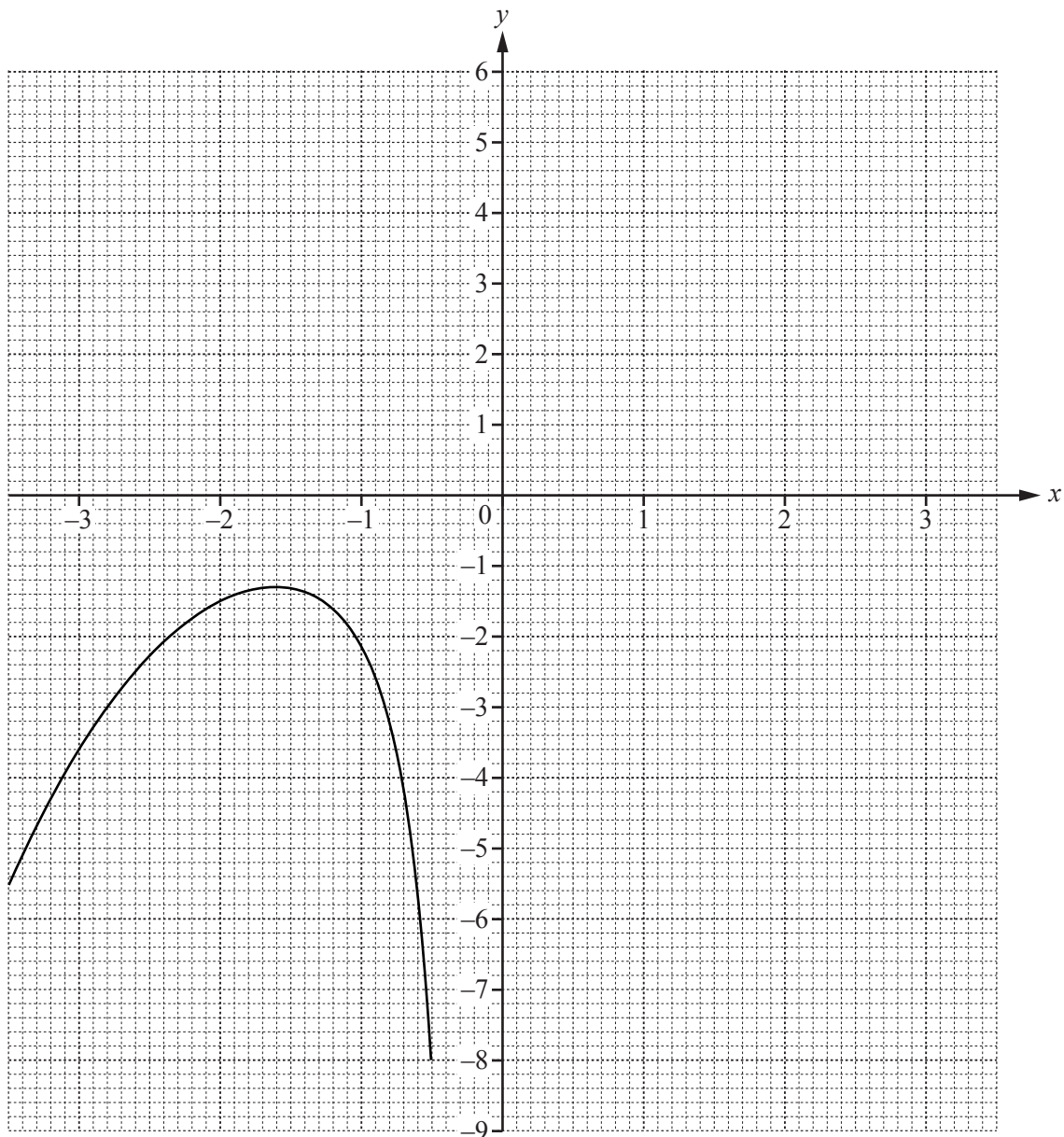

The graph of $y = \frac{x^3}{8} - \frac{2}{x^2}$ for $-3.5 \leq x \leq -0.5$ has already been drawn.

On the grid, draw the graph of $y = \frac{x^3}{8} - \frac{2}{x^2}$ for $0.5 \leq x \leq 3.5$.

[4]

(c) Use your graph to solve the equation $\frac{x^3}{8} - \frac{2}{x^2} = 0$.

$x = \dots\dots\dots$ [1]

(d) $\frac{x^3}{8} - \frac{2}{x^2} = k$ and k is an integer.

Write down a value of k when the equation $\frac{x^3}{8} - \frac{2}{x^2} = k$ has

(i) one answer,

$k = \dots\dots\dots$ [1]

(ii) three answers.

$k = \dots\dots\dots$ [1]

(e) By drawing a suitable tangent, estimate the gradient of the curve where $x = -3$.

$\dots\dots\dots$ [3]

(f) (i) By drawing a suitable line on the grid, find x when $\frac{x^3}{8} - \frac{2}{x^2} = 6 - x$.

$x = \dots\dots\dots$ [3]

(ii) The equation $\frac{x^3}{8} - \frac{2}{x^2} = 6 - x$ can be written as $x^5 + ax^3 + bx^2 + c = 0$.

Find the values of a , b and c .

$a = \dots\dots\dots$

$b = \dots\dots\dots$

$c = \dots\dots\dots$ [4]

- 6 (a) There are 100 students in group *A*.
 The teacher records the distance, d metres, each student runs in one minute.
 The results are shown in the cumulative frequency diagram.

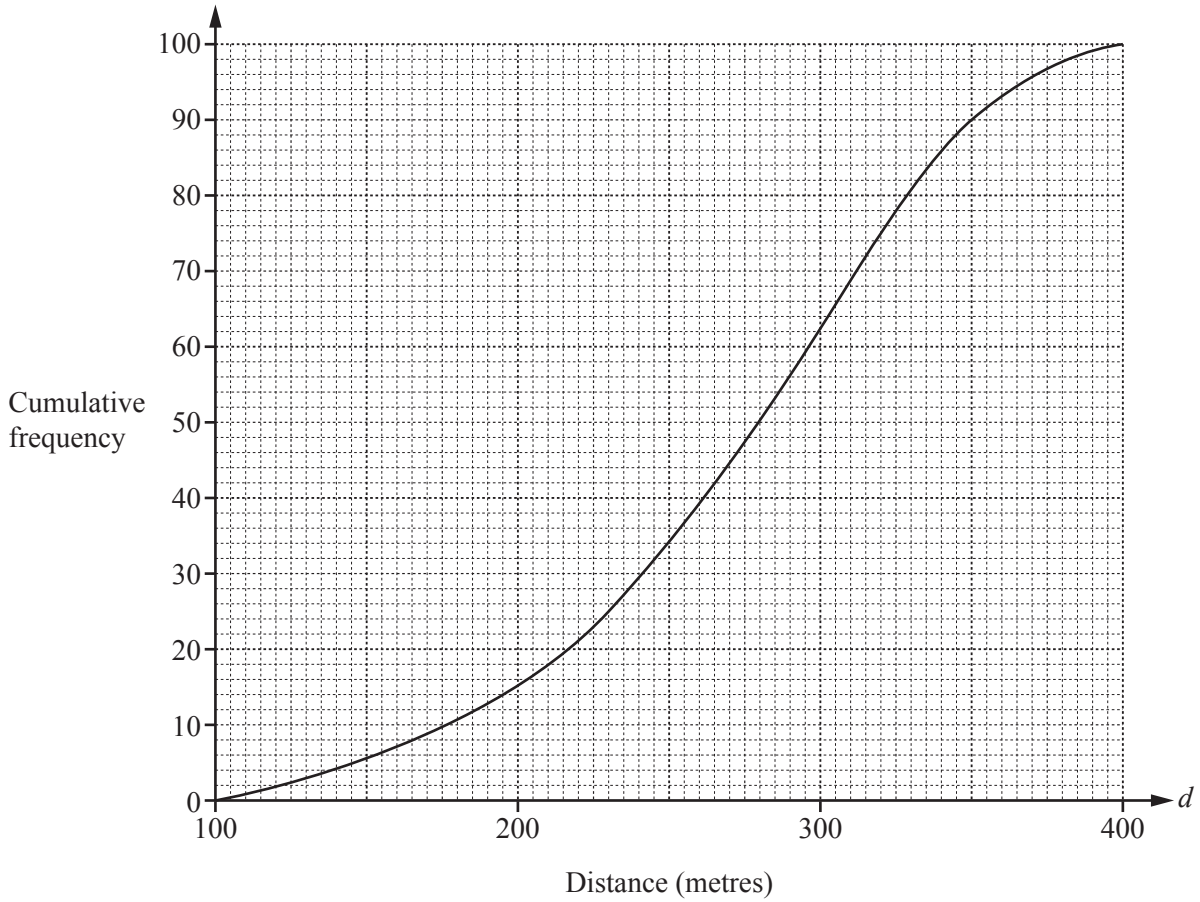

Find

- (i) the median,
 m [1]
- (ii) the upper quartile,
 m [1]
- (iii) the inter-quartile range,
 m [1]
- (iv) the number of students who run more than 350 m.
 [2]

- Q6** (b) There are 100 students in group *B*.
 The teacher records the distance, d metres, each of these students runs in one minute.
 The results are shown in the frequency table.

Distance (d metres)	$100 < d \leq 200$	$200 < d \leq 250$	$250 < d \leq 280$	$280 < d \leq 320$	$320 < d \leq 400$
Number of students	20	22	30	16	12

- (i) Calculate an estimate of the mean distance for group *B*.

..... m [4]

- (ii) Complete the histogram to show the information in the frequency table.



[4]

- (c) For the 100 students in group *B*, the median is 258 m.

Complete the statement.

On average, the students in group *A* run than the students in group *B*. [1]

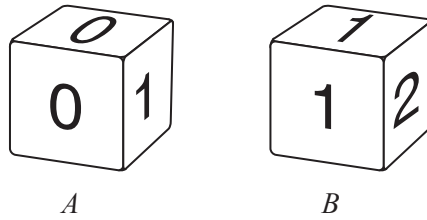

The diagram shows two fair dice.
 The numbers on dice *A* are 0, 0, 1, 1, 1, 3.
 The numbers on dice *B* are 1, 1, 2, 2, 2, 3.
 When a dice is rolled, the score is the number on the top face.

- (a) Dice *A* is rolled once.

Find the probability that the score is not 3.

..... [1]

- (b) Dice *A* is rolled twice.

Find the probability that the score is 0 both times.

..... [2]

- (c) Dice *A* is rolled 60 times.

Calculate an estimate of the number of times the score is 0.

..... [1]

(d) Dice *A* and dice *B* are each rolled once.
The product of the scores is recorded.

(i) Complete the possibility diagram.

Dice <i>B</i>	3	0	0				
	2	0	0				
	2	0	0				
	2	0	0				
	1	0	0				
	1	0	0	1	1	1	3
		0	0	1	1	1	3
		Dice <i>A</i>					

[2]

(ii) Find the probability that the product of the scores is

(a) 2,

..... [1]

(b) greater than 3.

..... [1]

(e) Eva keeps rolling dice *B* until 1 is scored.

Find the probability that this happens on the 5th roll.

..... [2]

- 8 (a) The cost of 1 apple is a cents.
 The cost of 1 pear is p cents.
 The total cost of 7 apples and 9 pears is 354 cents.

(i) Write down an equation in terms of a and p .

..... [1]

(ii) The cost of 1 pear is 2 cents more than the cost of 1 apple.

Find the value of a and the value of p .

$a =$

$p =$ [3]

- Q8** (b) Rowena walks 2 km at an average speed of x km/h.

(i) Write down an expression, in terms of x , for the time taken.

..... h [1]

(ii) Rowena then walks 3 km at an average speed of $(x - 1)$ km/h.
 The total time taken to walk the 5 km is 2 hours.

(a) Show that $2x^2 - 7x + 2 = 0$.

- Q8(b)** Find the value of x .
Show all your working and give your answer correct to 2 decimal places.

0580/42/O/N/17

$x = \dots\dots\dots$ [4]

9 $f(x) = 1 - 2x$ $g(x) = x + 4$ $h(x) = x^2 + 1$

(a) Find $f(-1)$.

..... [1]

(b) Solve the equation.

$$2f(x) = g(x)$$

$x =$ [2]

(c) Find $fg(x)$.

Give your answer in its simplest form.

..... [2]

(d) Find $hh(2)$.

..... [2]

(e) Find $f^{-1}(x)$.

$f^{-1}(x) =$ [2]

(f) $hgf(x) = 4x^2 + px + q$

0580/42/O/N/17

Find the value of p and the value of q .

$p = \dots\dots\dots$

$q = \dots\dots\dots$ [4]

Question 10 is printed on the next page.

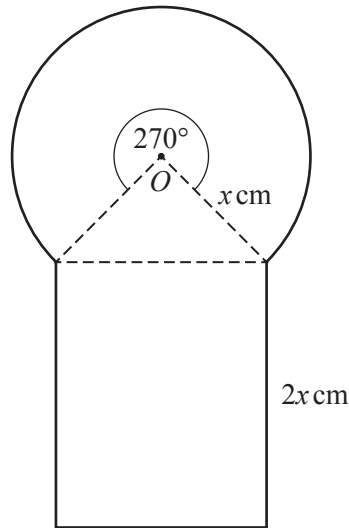

NOT TO
SCALE

The diagram shows a sector of a circle, a triangle and a rectangle.
The sector has centre O , radius x cm and angle 270° .
The rectangle has length $2x$ cm.

The total area of the shape is kx^2 cm².

(a) Find the value of k .

0580/42/O/N/17

$k = \dots\dots\dots$ [5]

(b) Find the value of x when the total area is 110 cm².

$x = \dots\dots\dots$ [2]

Permission to reproduce items where third-party owned material protected by copyright is included has been sought and cleared where possible. Every reasonable effort has been made by the publisher (UCLES) to trace copyright holders, but if any items requiring clearance have unwittingly been included, the publisher will be pleased to make amends at the earliest possible opportunity.

To avoid the issue of disclosure of answer-related information to candidates, all copyright acknowledgements are reproduced online in the Cambridge International Examinations Copyright Acknowledgements Booklet. This is produced for each series of examinations and is freely available to download at www.cie.org.uk after the live examination series.

Cambridge International Examinations is part of the Cambridge Assessment Group. Cambridge Assessment is the brand name of University of Cambridge Local Examinations Syndicate (UCLES), which is itself a department of the University of Cambridge.