

Fractional distillation

Fractional distillation : It is a method of separating two miscible liquids with a difference in their boiling points.

Fraction: Each distillate that is collected is called as fraction.

Experimental setup:

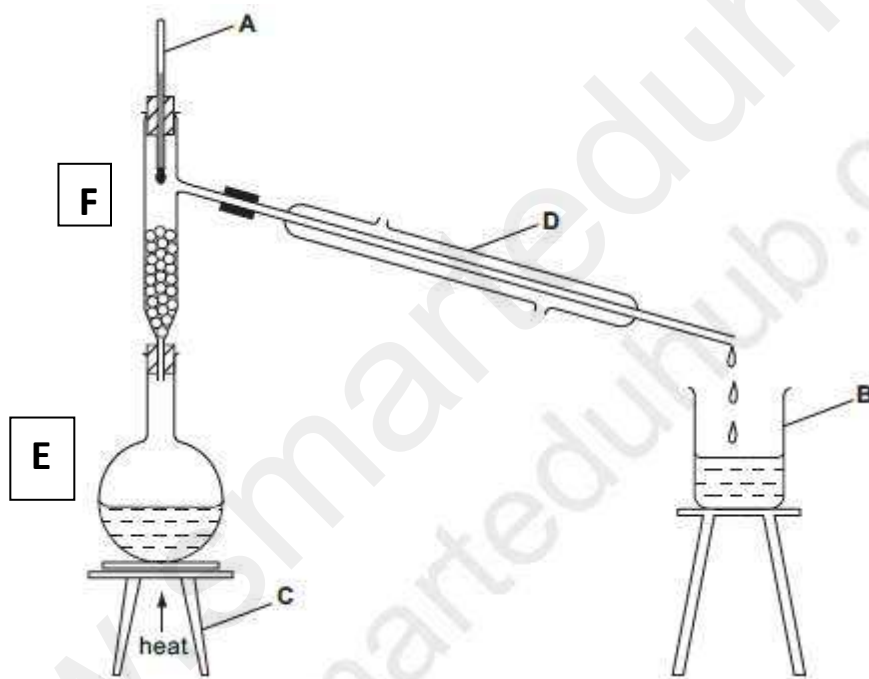

The apparatus consists of:

A- Thermometer

B- Beaker

C- Tripod

D- Condenser

E- Round bottom flask

F- Fractionating Column

Principle of operation: Two miscible liquids can be separated if they have a difference in their boiling points

Use of fractional distillation:

- To separate ethanol from fermented mixture
 - To separate a mixture of two liquids with a difference in their boiling points.
-

Purpose of the:

- Condenser:** The condenser condenses the vapour coming out of the fractionating column.
 - Fractionating column containing beads:** The glass beads provide a large surface area for the vaporisation and condensation of the liquid mixture. Small glass beads are preferred over large glass beads as they provide a large surface area
 - Thermometer:** To check if the complete separation of the substances has occurred or no.
-

Procedure:

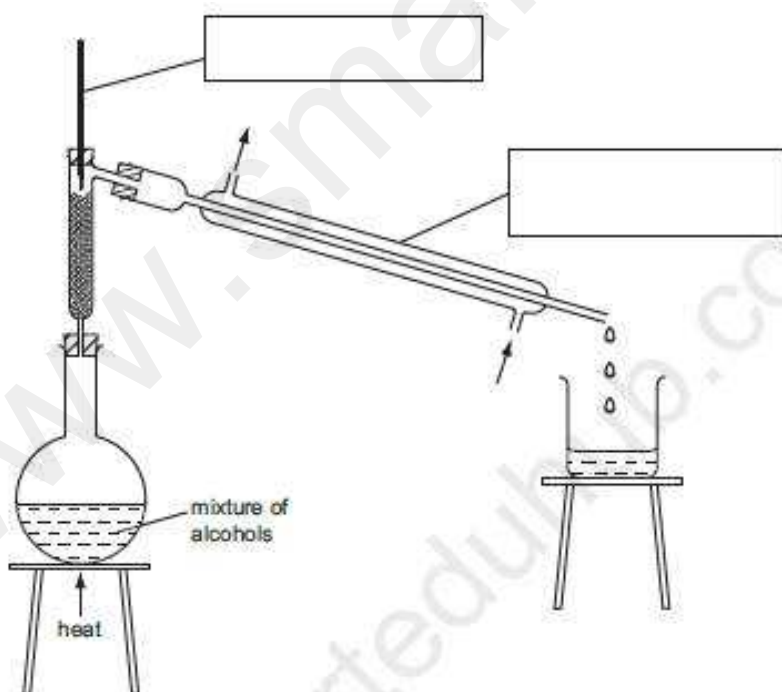

Example:

If you have to separate ethanol (Boiling point 78°C) and butanol (boiling point 118°C).

As temperature increases and till it is below 78°C , ethanol and butanol both evaporate and condense.

There is a range of temperatures in the fractionating column. The greatest temperature is lower down while the temperature decreases as you go up it.

When temperature reaches 78°C , the ethanol starts evaporating and at this temperature it boils off and passes to the condenser as ethanol vapour. The ethanol vapour condenses and changes into liquid ethanol. This liquid ethanol then gets called as the distillate.

The butanol which has evaporated condenses upon reaching the glass beads and falls back in the flask. Thus it is prevented from reaching the condenser. The temperature stays constant till all the ethanol has evaporated. The temperature will only begin to rise when all the ethanol has evaporated.

A possible hazard in this experiment is that the alcohols are flammable due to the heat of the bunsen burner.

Method to check the purity of the liquid obtained:

We may measure the boiling point of the liquid obtained to check its purity.
