

Experimental techniques

Know your lab apparatus well

- Volume is measured using a burette, measuring cylinder and pipette.
- Burette can measure volumes upto 50ml.
- Volumetric pipettes generally come in 10cm³ and 25cm³ sizes.
- Note 1ml=1cm³



burette



clock



pipette



thermometer

Simple distillation unit

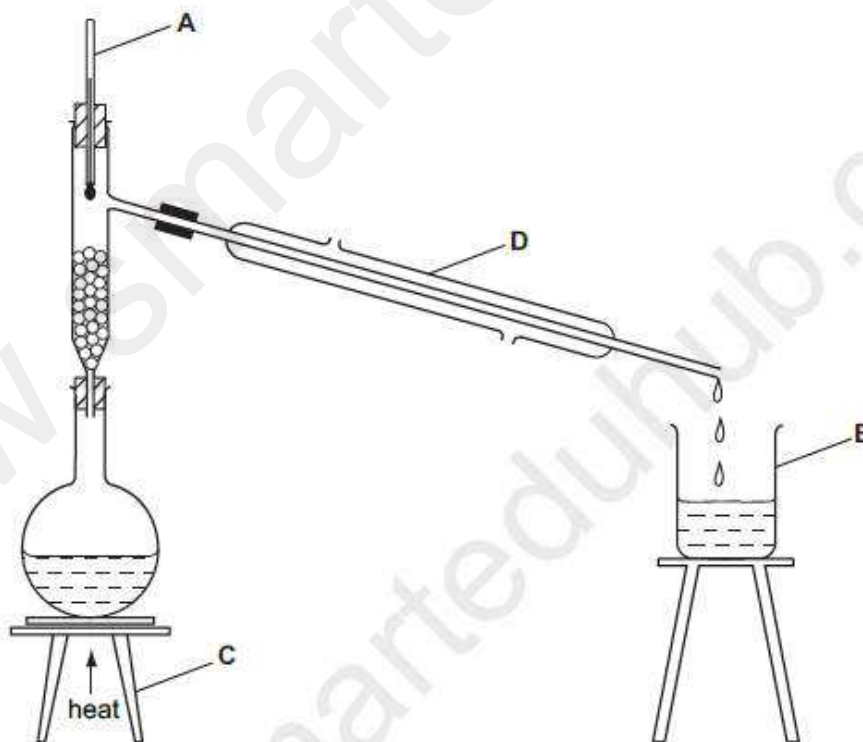

Apparatus and related experiments

Obtain crystals from a solution.

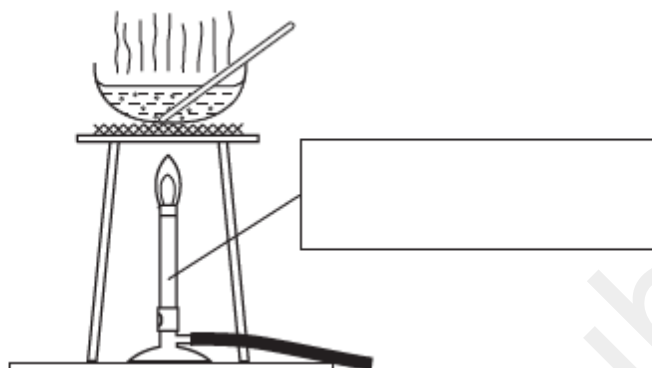

Separate a mixture of coloured dyes.

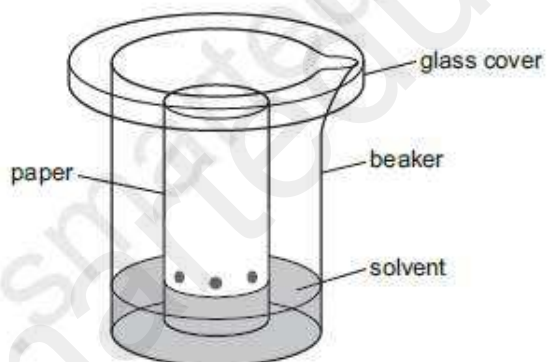

Apparatus for fractional distillation:

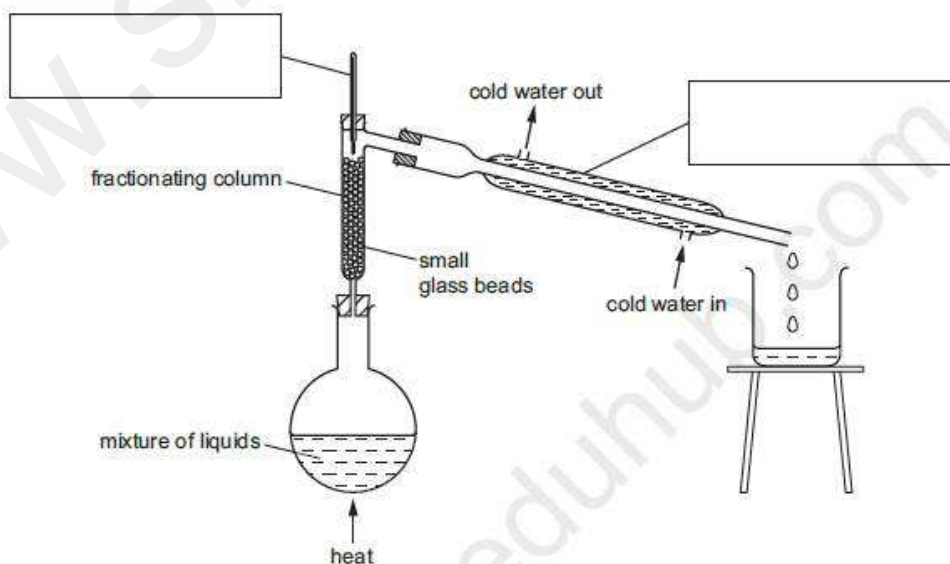

Thermal decomposition set up:

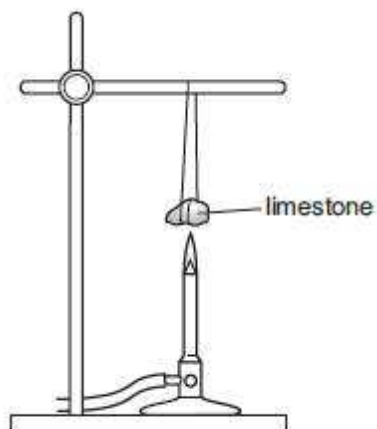

Pestle and mortar for grinding:



Filtration apparatus:



Measuring the volume of a gas in a reaction

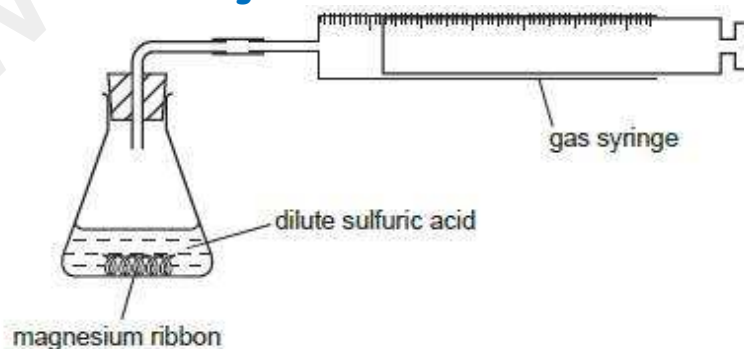

Apparatus needed to test for measure the rate of reaction where a precipitate is being formed.

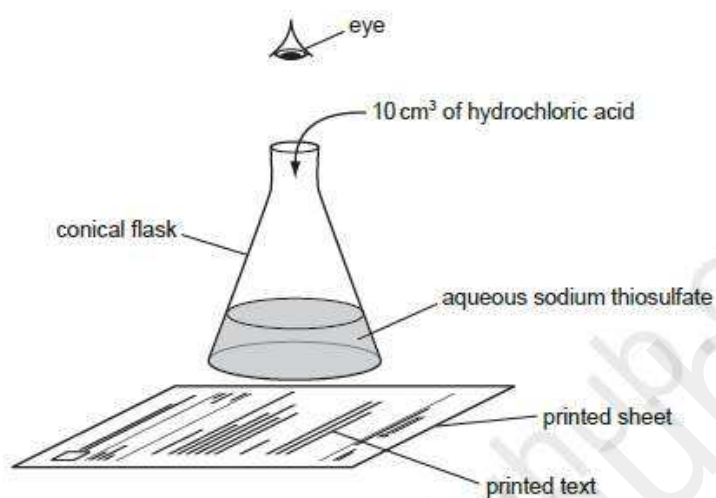

Read the scale on a measuring cylinder:

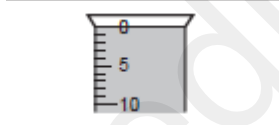

Apparatus for measuring the rate of reaction of an acid with marble chips:

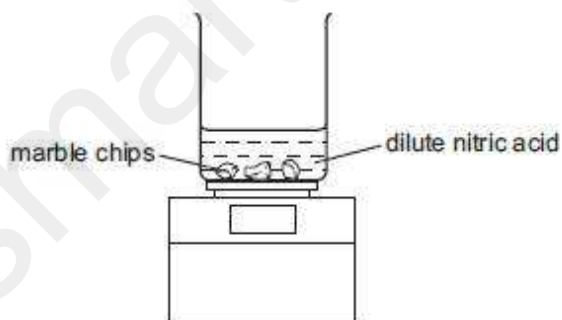

A retort stand:

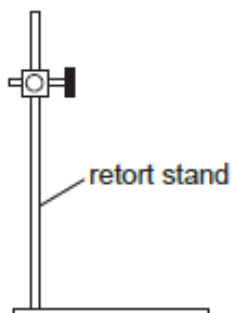

A spirit burner:



Extract colours from a given substance:

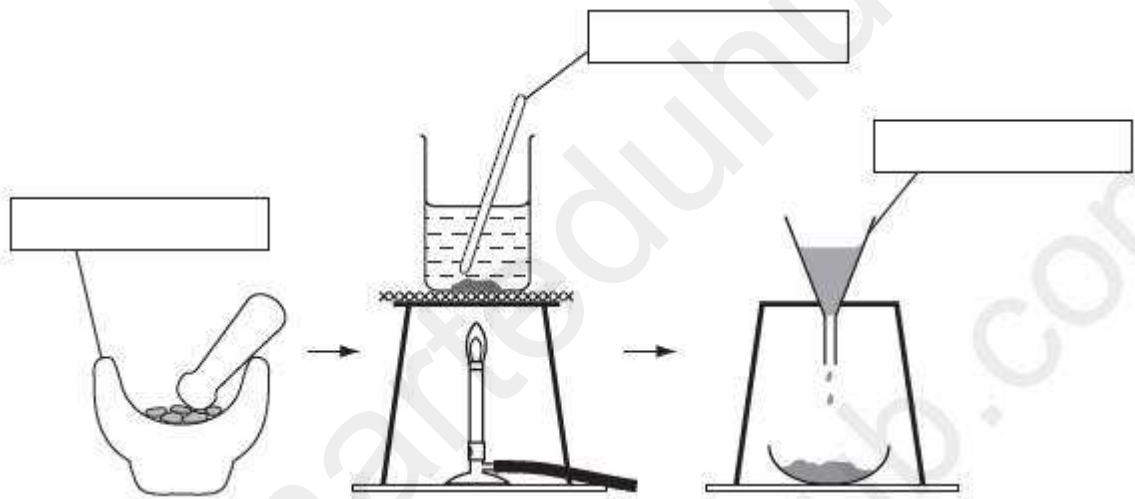

Preparing a hydroxide from a metal:

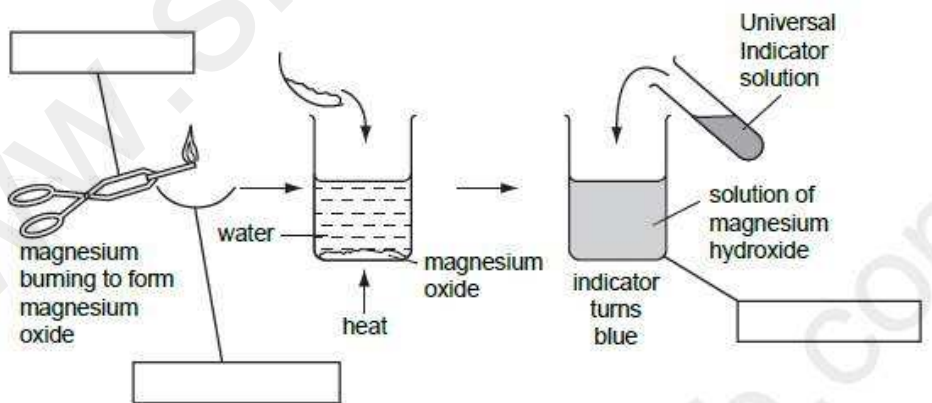

Making a salt from a metal oxide and an acid:

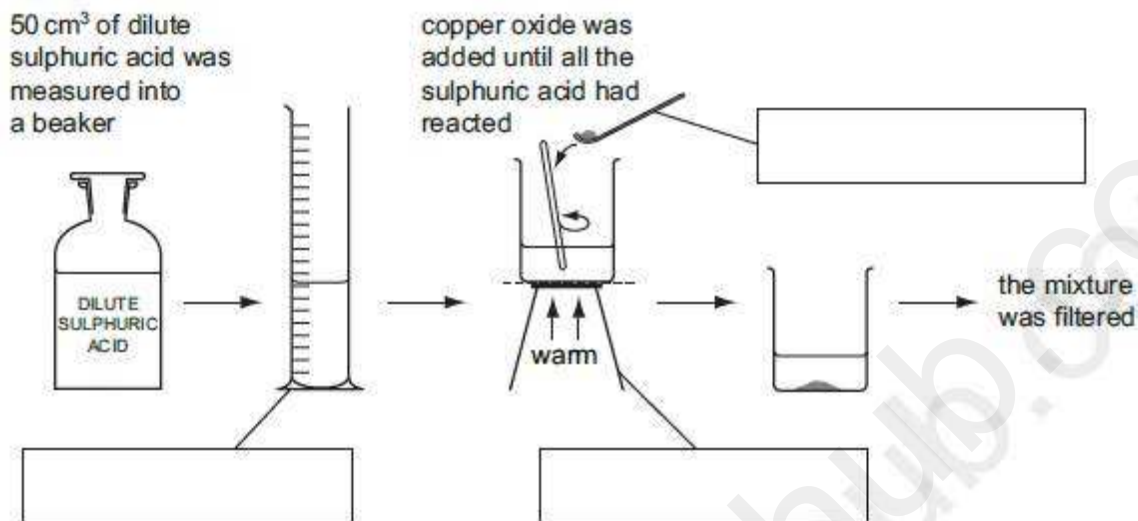

Read a chromatogram:

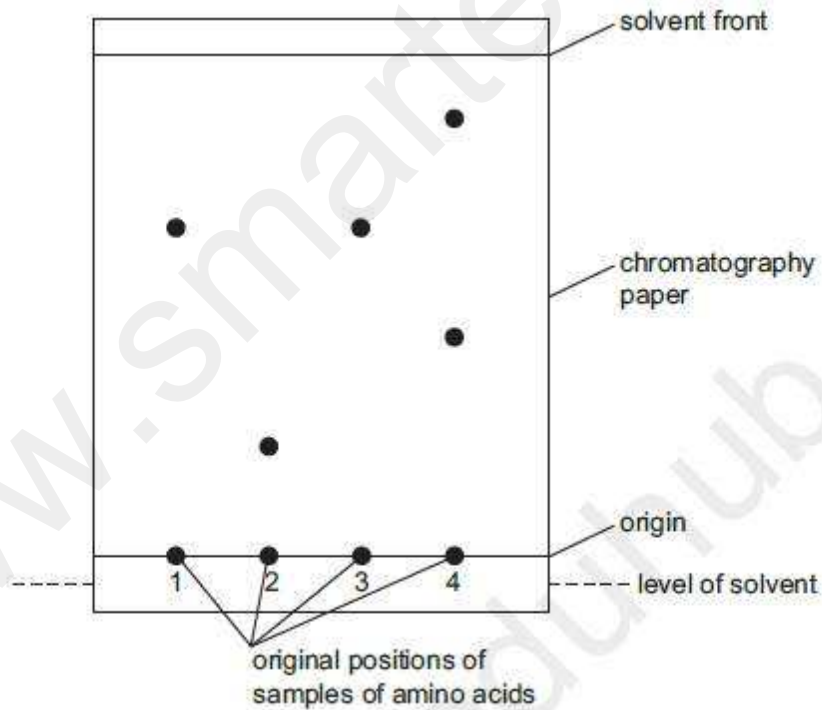

Reading scales and recording readings:

(b) Use the burette diagrams to record the volumes in the table and complete the table.



initial reading

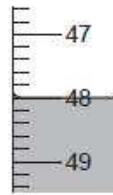

final reading

	burette readings / cm ³	
	experiment 1	experiment 2
final reading		

Extracting colours present in a leaf:

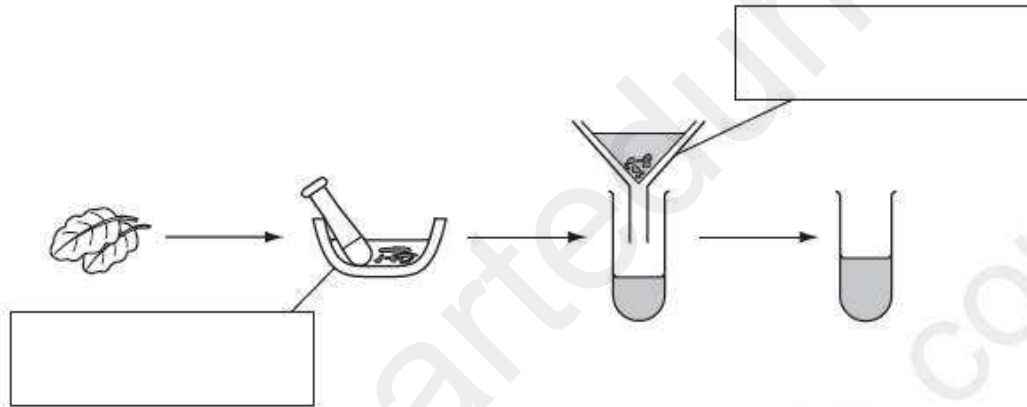

Setup for a diffusion experiment:

