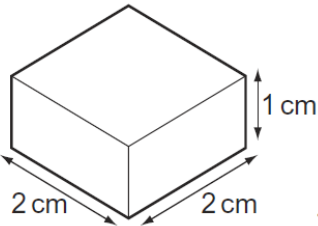
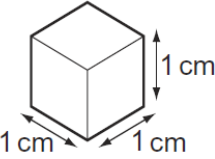
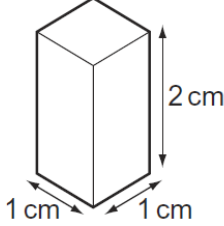
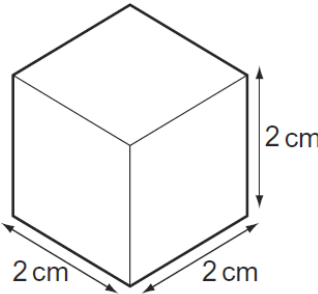

MEASURING DENSITY-SET-2

1	<p>What apparatus is needed to determine the density of a regularly-shaped block?</p> <p>A a balance and a ruler</p> <p>B a balance and a forcemeter (spring balance)</p> <p>C a measuring cylinder and a ruler</p> <p>D a measuring cylinder and a beaker</p>
2	<p>Which of the following is a unit of density?</p> <p>A cm^3/g</p> <p>B g/cm^2</p> <p>C g/cm^3</p> <p>D kg/m^2</p>
3	<p>The masses of a measuring cylinder before and after pouring some liquid into it are shown in the diagram.</p> <div data-bbox="564 1093 1133 1400" style="text-align: center;"><p>The diagram shows two measuring cylinders. The left cylinder is empty and has a mass of 80 g. The right cylinder contains a liquid and has a mass of 180 g. Both cylinders have a scale in cm³ with markings at 100 and 200. The liquid level in the right cylinder is at 100 cm³.</p></div> <p>What is the density of the liquid?</p> <p>A $\frac{100}{120} \text{ g}/\text{cm}^3$ B $\frac{100}{140} \text{ g}/\text{cm}^3$ C $\frac{180}{120} \text{ g}/\text{cm}^3$ D $\frac{180}{140} \text{ g}/\text{cm}^3$</p>

4	<p>A person measures the length, width, height and mass of a rectangular metal block.</p> <p>Which of these measurements are needed in order to calculate the density of the metal?</p> <p>A mass only</p> <p>B height and mass only</p> <p>C length, width and height only</p> <p>D length, width, height and mass</p>
---	---

5	<p>Each of the solids shown in the diagram has the same mass.</p> <p>Which solid has the greatest density?</p> <div style="display: flex; justify-content: space-around; align-items: flex-end;"> <div style="text-align: center;"> <p>A</p>  </div> <div style="text-align: center;"> <p>B</p>  </div> <div style="text-align: center;"> <p>C</p>  </div> <div style="text-align: center;"> <p>D</p>  </div> </div>
---	---

6	<p>A stone has a volume of 0.50 cm^3 and a mass of 2.0 g.</p> <p>What is the density of the stone?</p> <p>A 0.25 g/cm^3</p> <p>B 1.5 g/cm^3</p> <p>C 2.5 g/cm^3</p> <p>D 4.0 g/cm^3</p>
---	---

7

A measuring cylinder has a mass of 120 g when empty.

When it contains 50 cm³ of a liquid, the total mass of the measuring cylinder and the liquid is 160 g.

What is the density of the liquid?

A $\frac{40}{50}$ g/cm³

B $\frac{50}{40}$ g/cm³

C $\frac{120}{50}$ g/cm³

D $\frac{160}{50}$ g/cm³

8

A liquid has a volume of 100 cm³ and a mass of 85 g.

The density of water is 1.0 g/cm³.

How does the density of the liquid compare with the density of water?

A Its density is higher than that of water.

B Its density is lower than that of water.

C Its density is the same as that of water.

D It is impossible to say with only this data.

9

The table gives the volumes and masses of four objects.

Which object has the greatest density?

	mass / g	volume / cm ³
A	5.4	2.0
B	13	3.0
C	15	6.0
D	18	5.0

10

A metal block has the dimensions shown. Its mass is 1000 g.

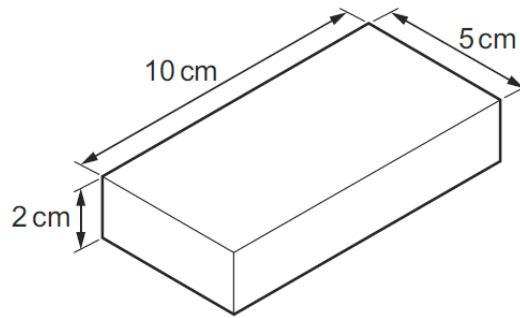

What is the density of the metal?

- A** $\left(\frac{5 \times 10}{1000 \times 2}\right) \text{g/cm}^3$
- B** $\left(\frac{2 \times 5 \times 10}{1000}\right) \text{g/cm}^3$
- C** $\left(\frac{1000 \times 2}{5 \times 10}\right) \text{g/cm}^3$
- D** $\left(\frac{1000}{2 \times 5 \times 10}\right) \text{g/cm}^3$

11

A measuring cylinder containing only water is placed on an electronic balance. A small, irregularly shaped stone is now completely immersed in the water.

The diagrams show the equipment before and after the stone is immersed.

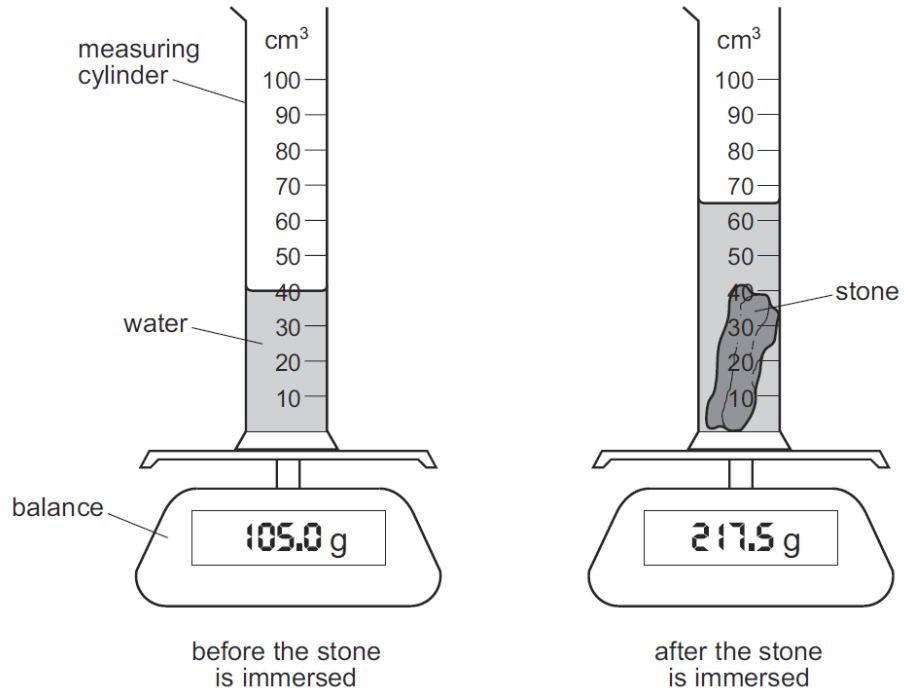

What is the density of the material of the stone?

- A** 1.7 g/cm³ **B** 3.3 g/cm³ **C** 4.5 g/cm³ **D** 8.7 g/cm³