

12.

A glass tank contains some water.

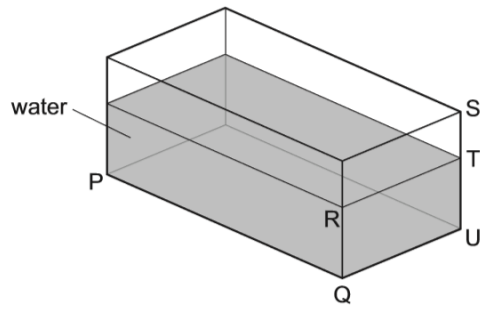

Only the length PQ and the width QU of the tank are known.

Which other distance must be known to calculate the volume of the water?

- A** RT      **B** ST      **C** SU      **D** TU

Ans

13.

The diagram shows two cubes of different sizes made from the same substance.

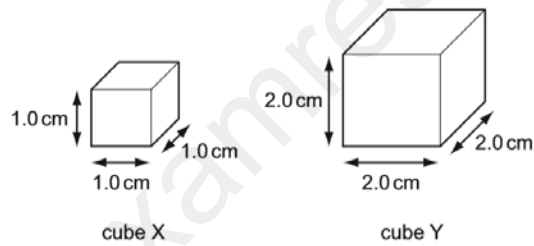

Cube X has a density of  $1.2 \text{ g/cm}^3$ .

What is the density of cube Y?

- A**  $1.2 \text{ g/cm}^3$     **B**  $2.4 \text{ g/cm}^3$     **C**  $4.8 \text{ g/cm}^3$     **D**  $9.6 \text{ g/cm}^3$

Ans

14.

A glass tank contains some water.

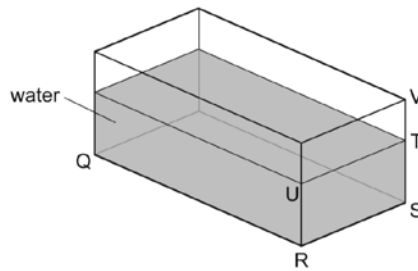

The length QR and the width RS of the tank are known.

What other distance needs to be known in order to be able to calculate the volume of the water?

- A** ST      **B** SV      **C** TU      **D** TV

Ans

15.

Which is the unit for force and which is the unit for weight?

	force	weight
<b>A</b>	kg	kg
<b>B</b>	kg	N
<b>C</b>	N	kg
<b>D</b>	N	N

Ans

16.

The table gives information about a liquid in a container.

depth of liquid	10 cm
mass of liquid	30 g
temperature of liquid	25 °C
volume of liquid	20 cm <sup>3</sup>

What is the density of the liquid?

- A** 0.33 cm/g      **B** 1.2 g/°C      **C** 1.5 g/cm<sup>3</sup>      **D** 3.0 g/cm

Ans

17.

Some water is poured into four tubes of different cross-sectional areas.

Which tube holds the largest volume of water?

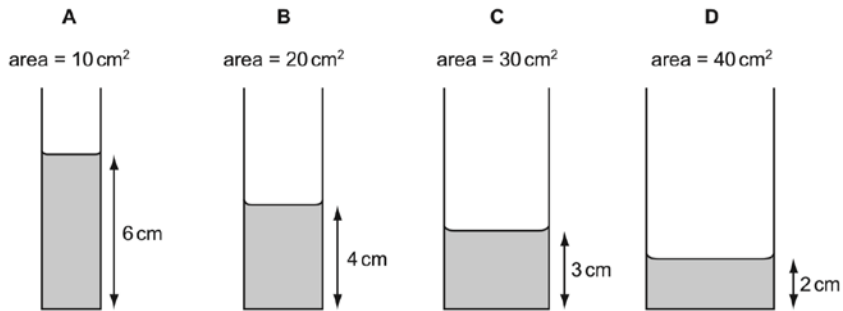

Ans

18.

What is the meaning of the *weight* of an object?

- A the density of the material from which it is made
- B the force exerted on it by gravity
- C the mass of the matter it contains
- D the pressure it exerts on the ground

Ans

19.

Which statement is correct?

- A The mass of a bottle of water at the North Pole is different from its mass at the Equator.
- B The mass of a bottle of water is measured in newtons.
- C The weight of a bottle of water and its mass are both measured in kilograms.
- D The weight of a bottle of water is one of the forces acting on the bottle.

Ans

20.

Which substance in the table has the lowest density?

	substance	mass / g	volume / cm <sup>3</sup>
<b>A</b>	nylon	1.2	1.0
<b>B</b>	cotton	1.5	1.0
<b>C</b>	olive oil	1.8	2.0
<b>D</b>	water	2.0	2.0

Ana

21.

Which row shows the unit for force, the unit for mass and the unit for weight?

	force	mass	weight
<b>A</b>	kg	kg	N
<b>B</b>	kg	N	kg
<b>C</b>	N	kg	N
<b>D</b>	N	N	kg

Ans

22.

The table gives the volumes and masses of four objects.

Which object has the greatest density?

	mass / g	volume / cm <sup>3</sup>
<b>A</b>	5.4	2.0
<b>B</b>	13	3.0
<b>C</b>	15	6.0
<b>D</b>	18	5.0

Ans

23.

Which conditions are necessary for an object to have weight?

	must have mass	must be in a gravitational field	must be in an electric field
<b>A</b>	no	yes	no
<b>B</b>	no	yes	yes
<b>C</b>	yes	no	yes
<b>D</b>	yes	yes	no

Ans

24.

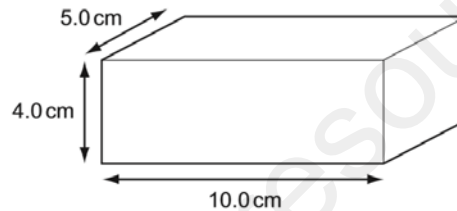
A rectangular metal block has the dimensions shown. The density of the metal is  $8.0 \text{ g/cm}^3$ .

What is the mass of the metal block?

- A** 160g      **B** 320g      **C** 400g      **D** 1600g

Ans

25.

The diagram shows two cubes P and Q. The lengths of their sides and their masses are given.

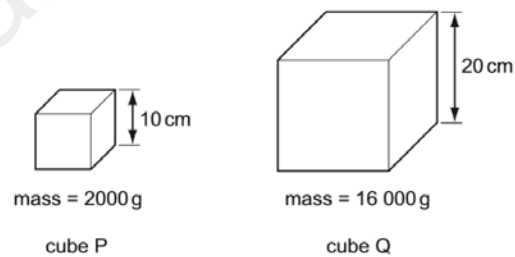

What is the density of the material of cube Q?

- A** half that of cube P  
**B** the same as that of cube P  
**C** twice that of cube P  
**D** four times that of cube P

Ans

26.

A shop-keeper places two identical blocks of cheese on a set of scales and notices that their combined mass is 240g. Each block measures  $2.0\text{ cm} \times 5.0\text{ cm} \times 10.0\text{ cm}$ .

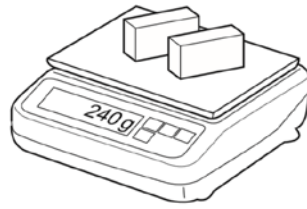

What is the density of the cheese?

- A**  $0.42\text{ g/cm}^3$    **B**  $0.83\text{ g/cm}^3$    **C**  $1.2\text{ g/cm}^3$    **D**  $2.4\text{ g/cm}^3$

Ans

27.

The diagram shows a measuring cylinder.

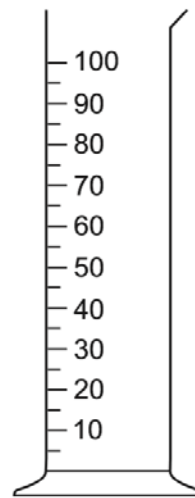

Which unit would be most suitable for its scale?

- A**  $\text{mm}^2$       **B**  $\text{mm}^3$       **C**  $\text{cm}^2$       **D**  $\text{cm}^3$

Ans:

D

28.

Which statement about the mass of a falling object is correct?

- A** It decreases as the object falls.  
**B** It is equal to the weight of the object.  
**C** It is measured in newtons.  
**D** It stays the same as the object falls.

Ans:

D

29.

Which of the following is a unit of density?

- A  $\text{cm}^3/\text{g}$
- B  $\text{g}/\text{cm}^2$
- C  $\text{g}/\text{cm}^3$
- D  $\text{kg}/\text{m}^2$

Ans:

C

30.

Which statement is correct?

- A The mass of a bottle of water at the North Pole is different from its mass at the Equator.
- B The mass of a bottle of water is measured in newtons.
- C The weight of a bottle of water and its mass are the same thing.
- D The weight of a bottle of water is one of the forces acting on it.

Ans:

D

31.

A decorator wishes to calculate the area of a bathroom tile so that he can estimate the amount of adhesive which he needs to buy.

What must he use?

- A a measuring cylinder only
- B a ruler only
- C a measuring cylinder and a clock only
- D a measuring cylinder and a ruler only

Ans:

B

32.

A person measures the length, width, height and mass of a rectangular metal block.

Which of these measurements are needed in order to calculate the density of the metal?

- A mass only
- B height and mass only
- C length, width and height only
- D length, width, height and mass

Ans:

D